

# WAF SERIES COMPRESSED AIR FILTRATION

**RISHENG®**

Westair Pneumatic Systems has teamed up with Risheng to introduce the WAF Filtration Series to improve quality and efficiency. All compressed air, unless purified is contaminated with oil, water and dirt particles.

Manufactured from high quality glass fibre and diecast aluminium components, the filter effectively removes any dirt particles and pollutants in the air. The filter elements are made of UK or USA needle felt cloth. For full corrosion protection, the filter shell surfaces are anodic oxidated treated and coated with epoxy resin. The design is user friendly, making it easy to replace filter elements and they are fitted with special anti-leakage technology to maximise the filtering effect.



## WAF SERIES FILTER

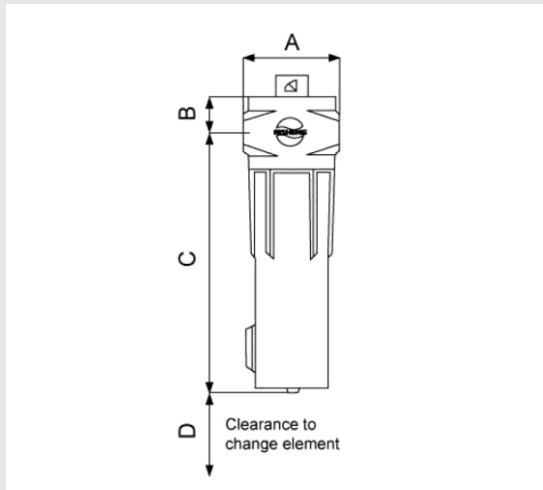

Image A: Models WAF\*17C- WAF\*620C

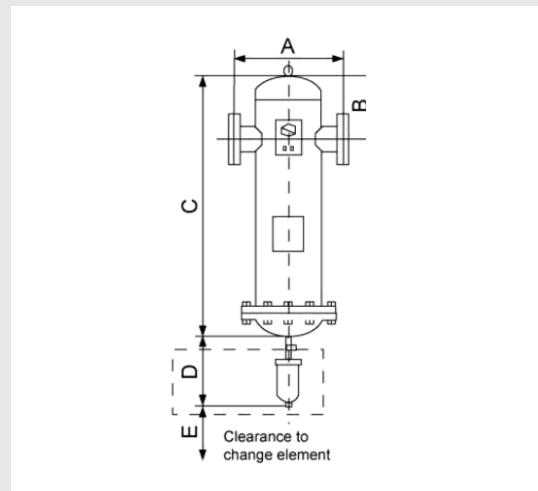

Image B: Models WAF\*1000C- WAF\*1300C

Model	Capacity		Air Connections	Dimensions (mm)					Weight Kg	Filter Element	
	Pre (AO) or Post (AA)	m3/min		CFM	A	B	C	D			E
WAF-*-17C		1.0	35	Rc 1/2"	89	42	160	95	1.1	WAF*17ELE	
WAF-*-30C		1.8	64	Rc 1/2"	89	42	193	130	1.5	WAF*30ELE	
WAF-*-58C		3.5	124	Rc 3/4"	120	58	252	172	2.5	WAF*58ELE	
WAF-*-80C		4.8	170	Rc 1"	120	58	352	272	3.2	WAF*145ELE	
WAF-*-145C		8.7	307	Rc 1 1/2"	120	58	352	272	3.2	WAF*145ELE	
WAF-*-220C		13.2	466	Rc 2"	162	74	424	320	6.6	WAF*220ELE	
WAF-*-330C		20.0	706	Rc 2"	162	74	738	625	10.9	WAF*330ELE	
WAF-*-430C		25.8	911	Rc 3"	200	90	488	400	12.9	WAF*430ELE	
WAF-*-620C		40.0	1413	Rc3"	200	90	749	625	17.5	WAF*620ELE	
WAF-*-1000C		60	2119	DN100	493	263	1119	340	650	115	WAF-*-330ELEC
WAF-*-1200C		70	2472	DN125	617	290	1179	340	650	145	WAF-*-330ELEC
WAF-*-1300C		80	2825	DN125	617	290	1179	340	650	150	WAF-*-330ELEC

Notes: \*Refers to filtration grade

# WAF SERIES COMPRESSED AIR FILTRATION

## Complete Filter

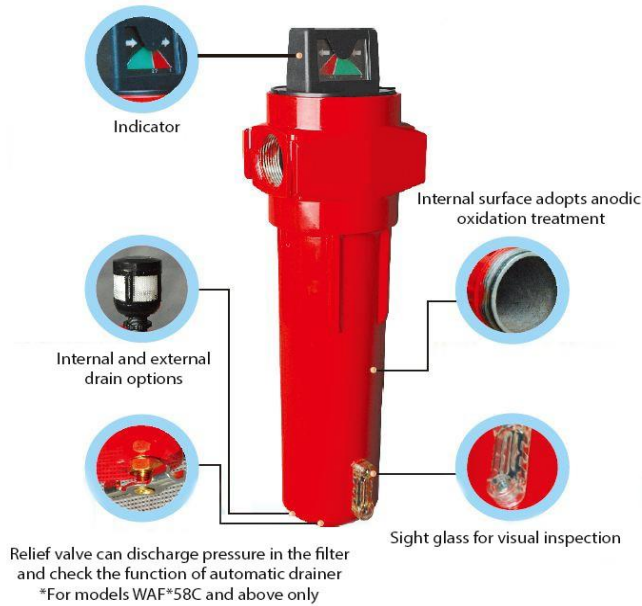

## Filter Element

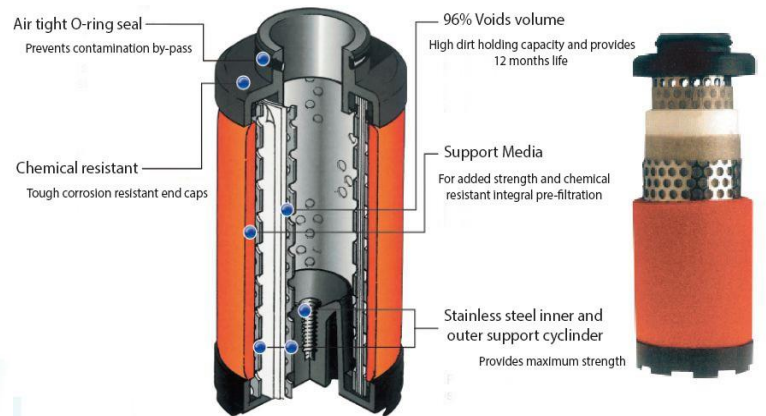

## TECHNICAL DATA

Product Level	Filtration Precision	Residual Oil Mist	Initial Pressure Drop (MPa)		Max. work temperature °C	Min. work temperature °C	Max. work pressure Mpa (g)	
			Dry Pressure Drop	Wet Pressure Drop				
Pre	AO	1 (µm)	0.5 (1atm, 21°C below, mg/m <sup>3</sup> )	0.007	0.014	66/120	1.5	1.6
Post	AA	0.01	0.01	0.01	0.02	66/120	1.5	1.6
Carbon	ACS	-	0.003	0.02	0.03	30	1.5	1.6



COMPRESSOR TECHNOLOGY QLD Pty Ltd

23-27 Victor Street Boronia Heights QLD 4124 Ph: (07) 3133 3527

Email: [sales@ctqgroup.com.au](mailto:sales@ctqgroup.com.au) Website: [www.ctqgroup.com.au](http://www.ctqgroup.com.au)